



Disney · PIXAR
Toy
STORY



7592



1

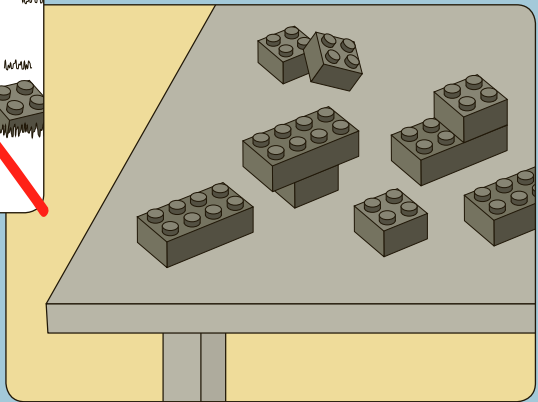
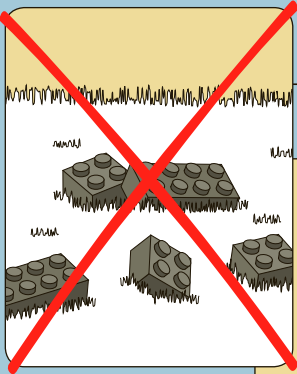

2



2



3





1x



1x

1



4x

2



1x



1x

3

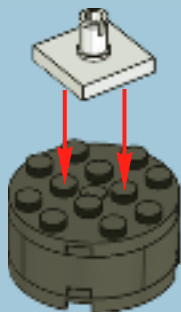

4



4x

4

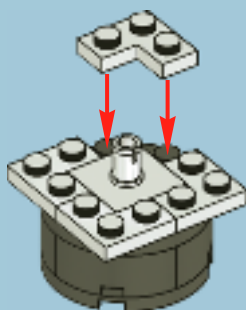

1x

5

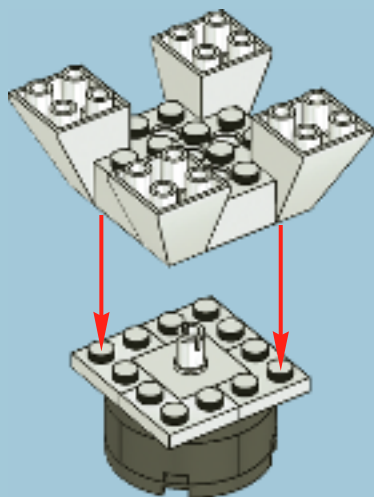



1x

6

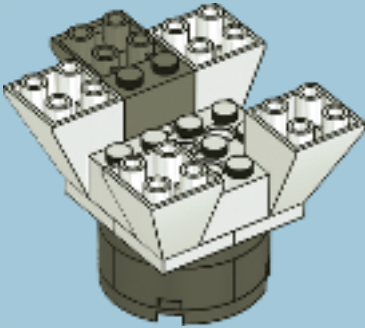

1x



1x



1x



1x

7

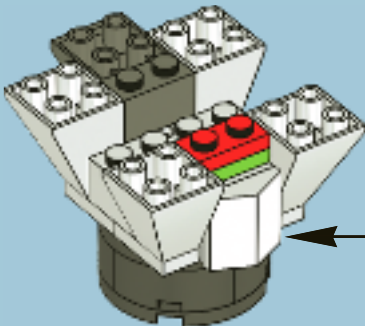

1

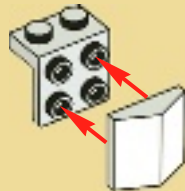

2



3



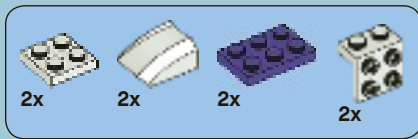

8

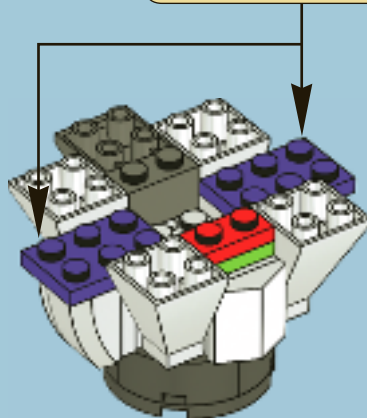
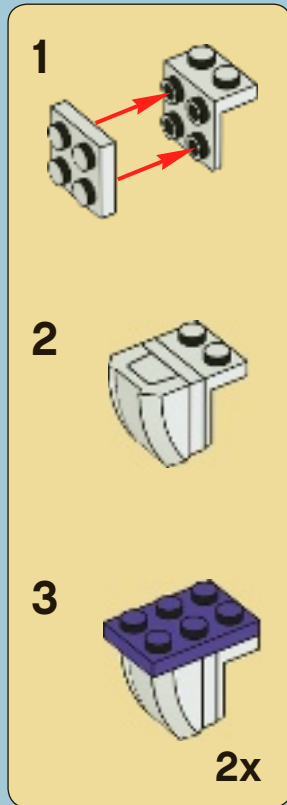



1x

9

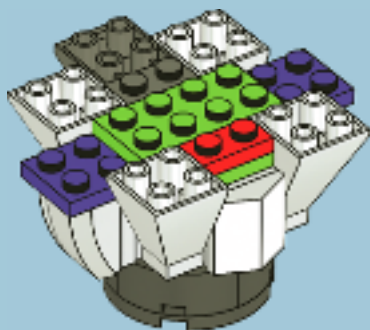

2x



1x

10

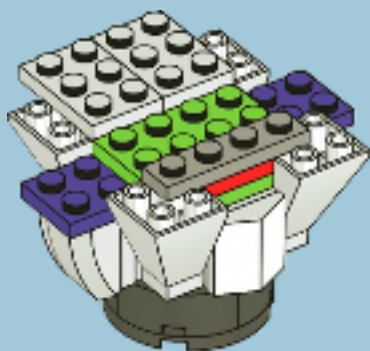



2x

11

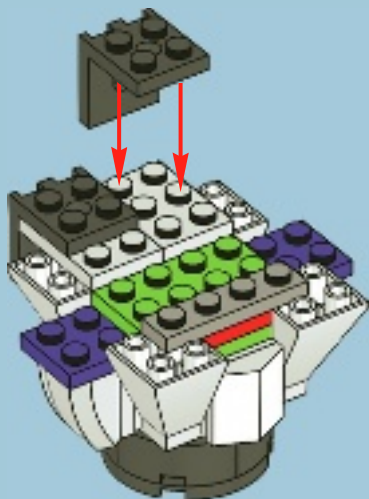

2x

12

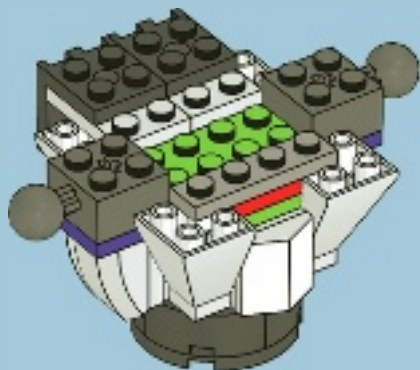



4x

13

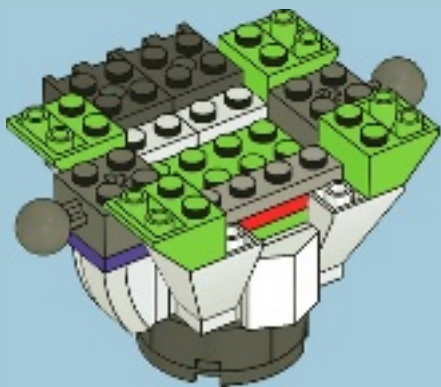

1x



2x

14

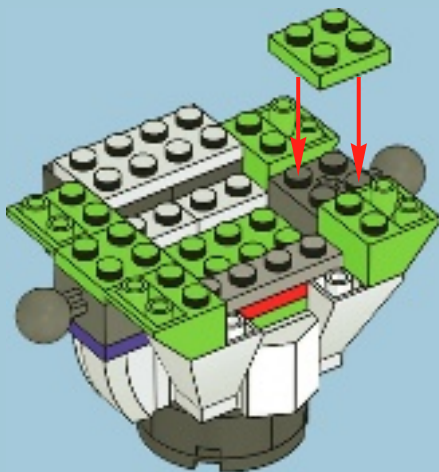



2x

15

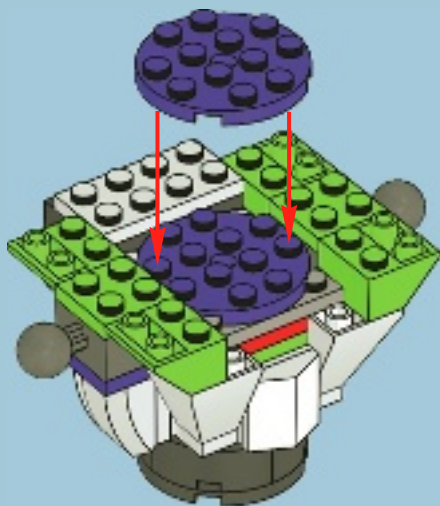

1x



1x

16

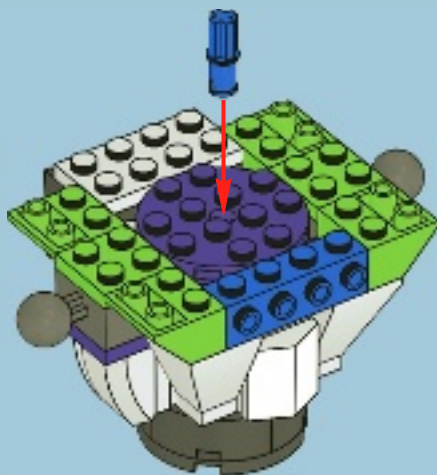

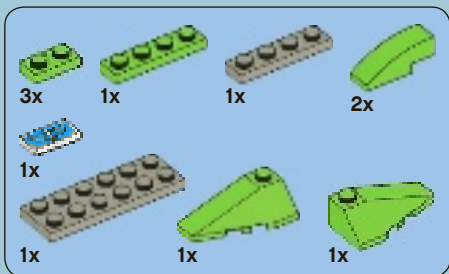

17

1

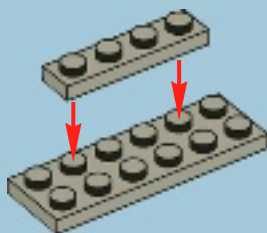

2

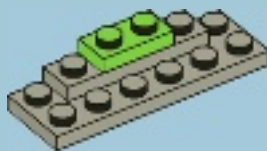

3

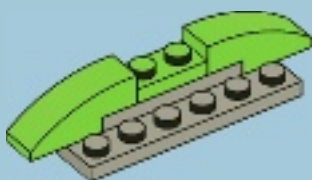

4

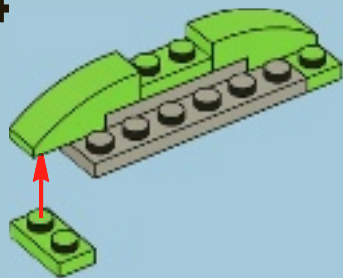

6

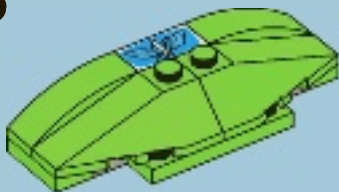

5

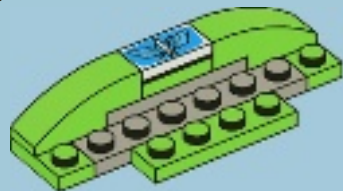

7

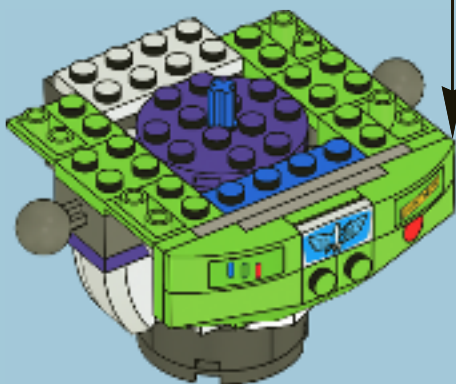
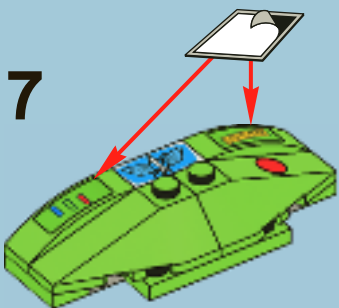

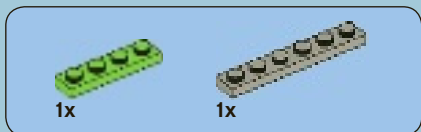

18

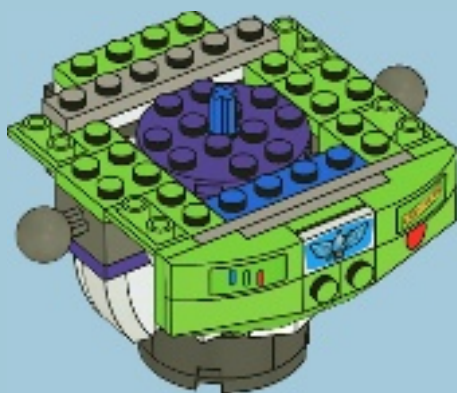

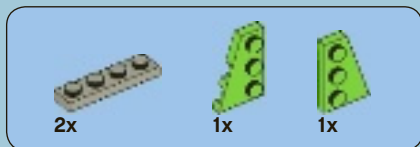

19

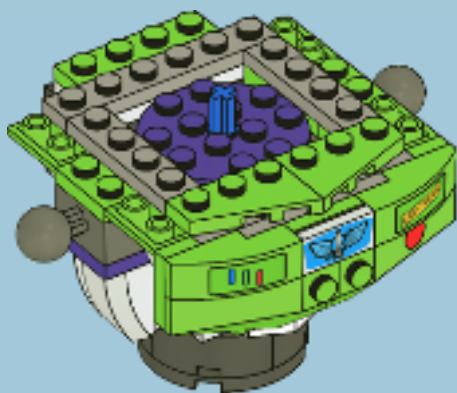

20

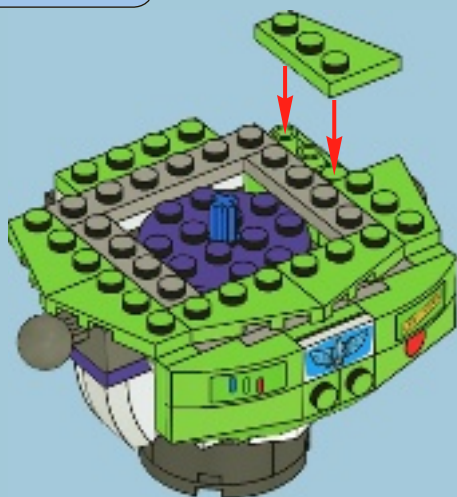



1x



2x

21

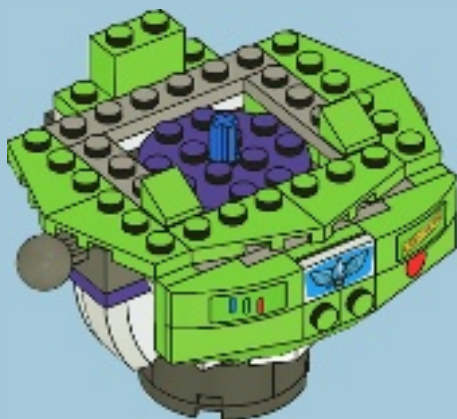

2x

22

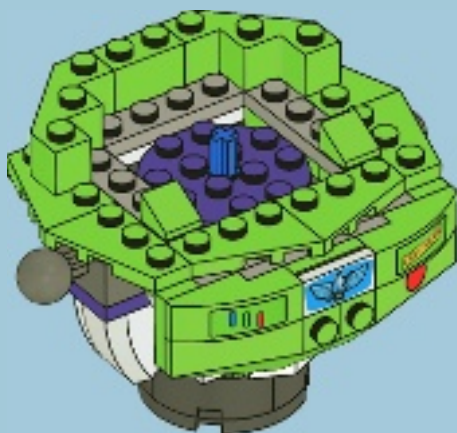

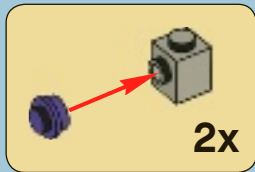
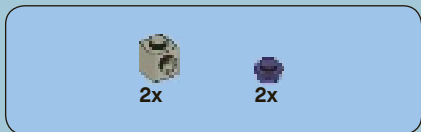

23

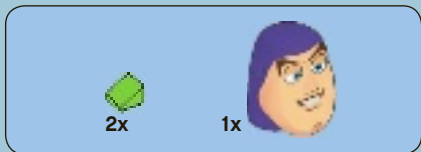
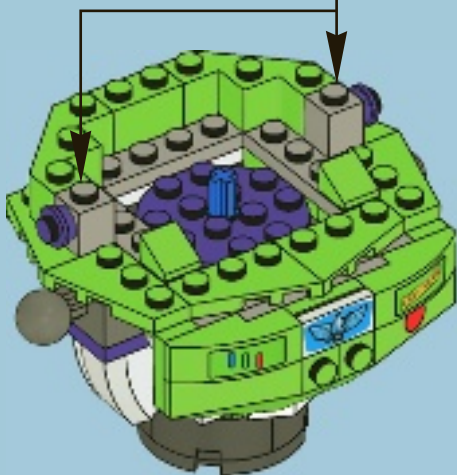

24



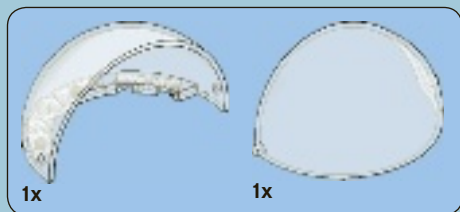

25

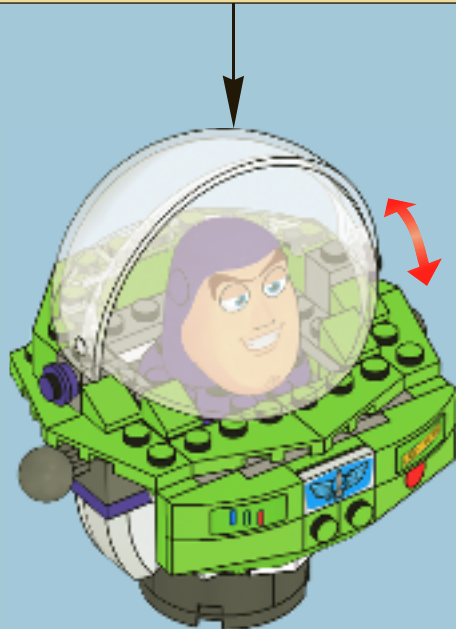
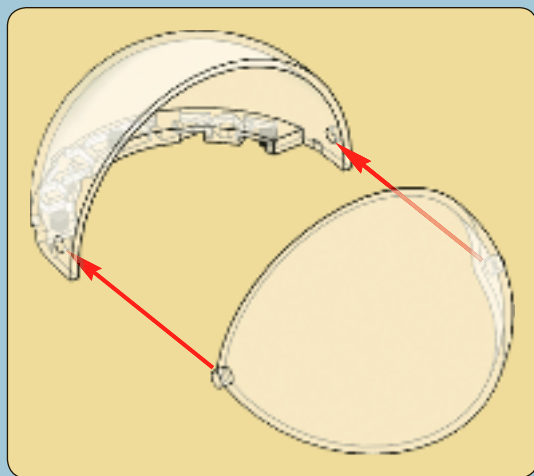

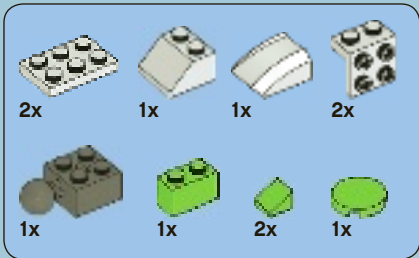
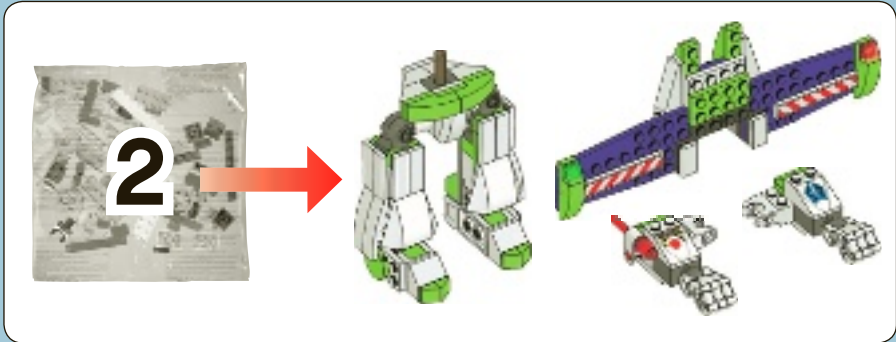

1



2

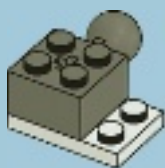

3

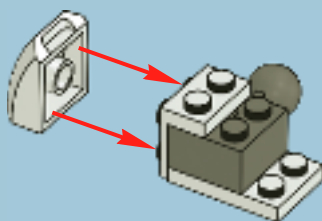

4



8

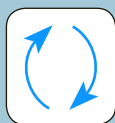
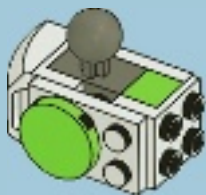

9

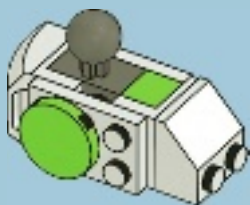

10

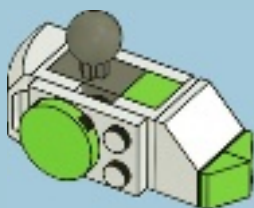

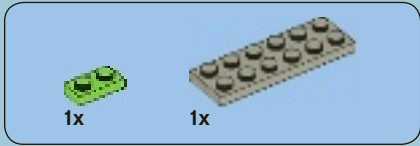

1

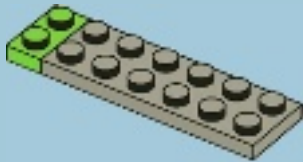

2

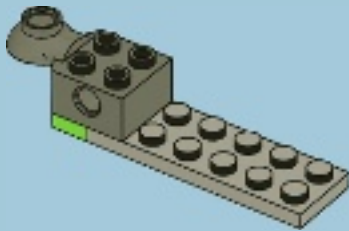



1x



1x

3

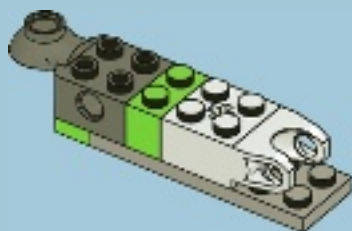

1x



1x

4

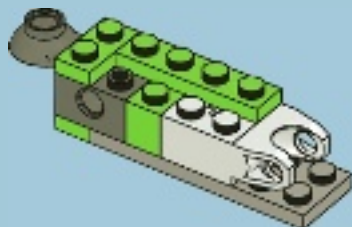



2x

5

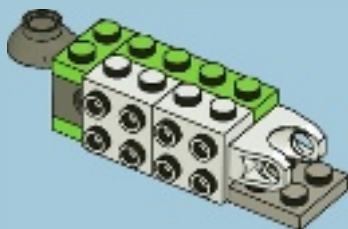

4x

6

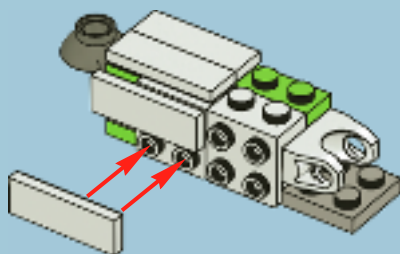

7

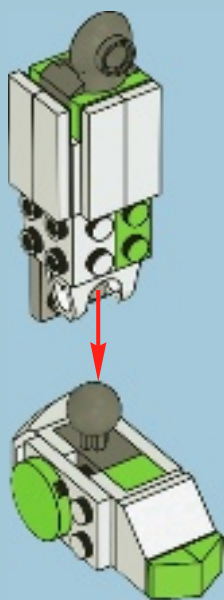



1x

8

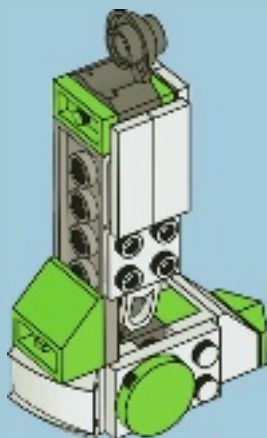
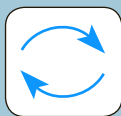

1x

9

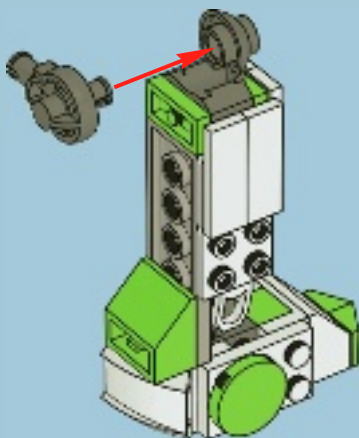



2x

10

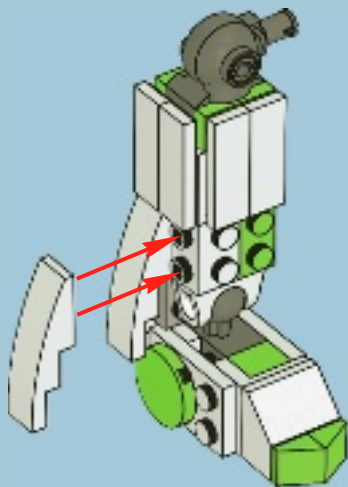
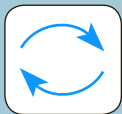

1x

11

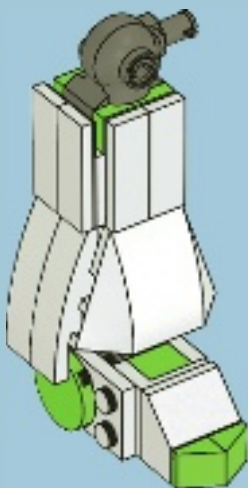



1x

1



2x

2

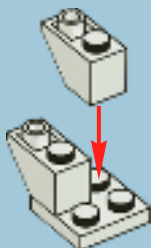



2x

3

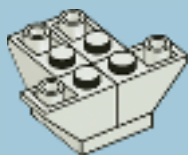

1x



1x



1x

4

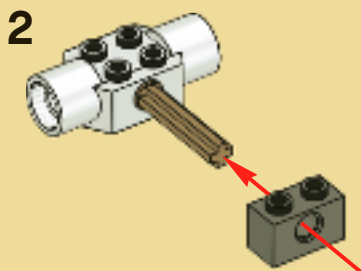
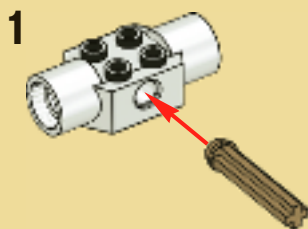



2x

5

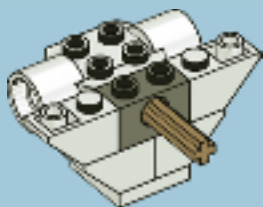

1x



2x

6

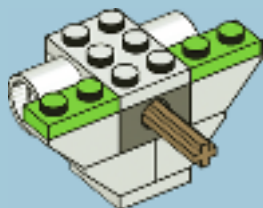



1x



1x

7

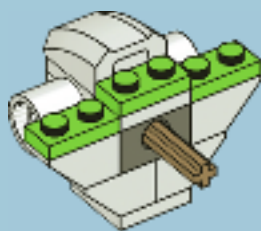

2x

8

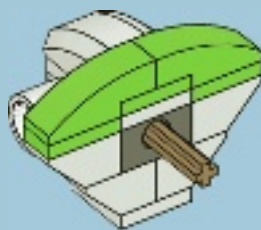

9

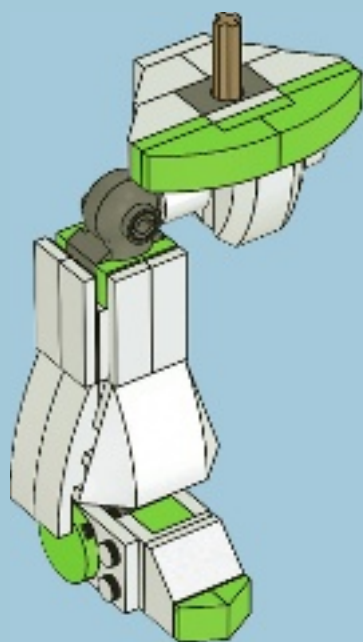

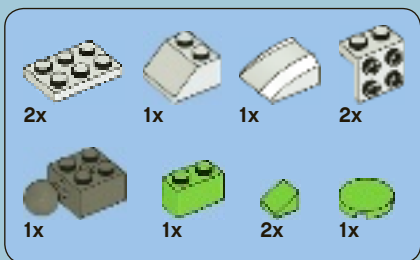

1



2



3

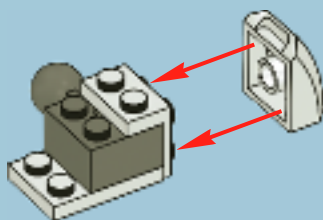

4



5

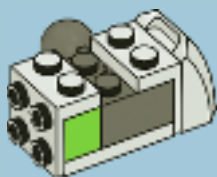

6

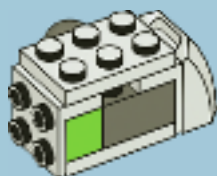

7



8

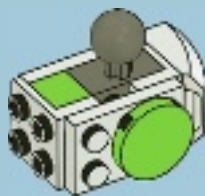

9

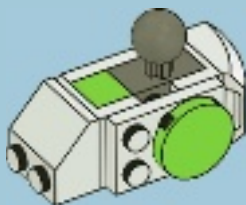

10

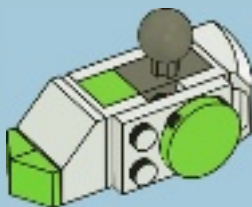



1x



1x

1

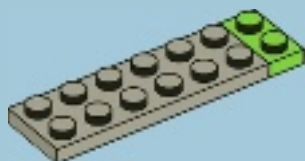

1x

2

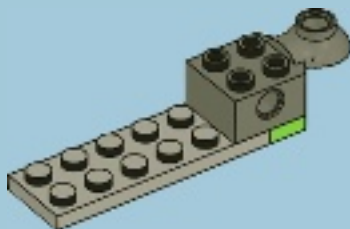



1x



1x

3



1x



1x

4

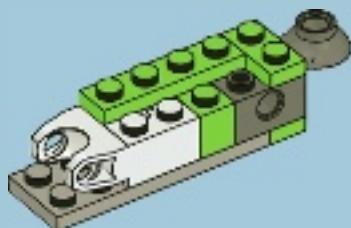

7

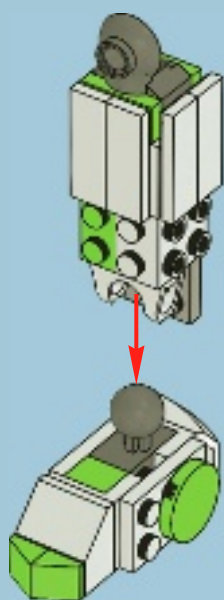



1x

8

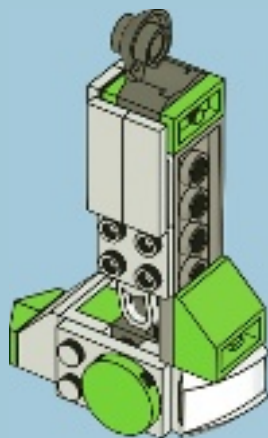

1x

9

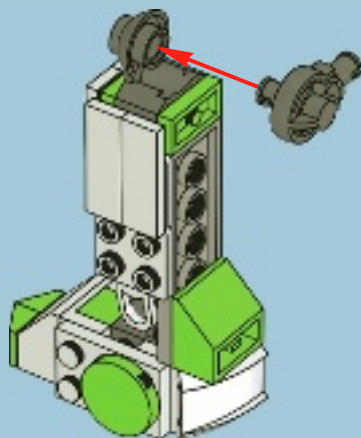



2x

10

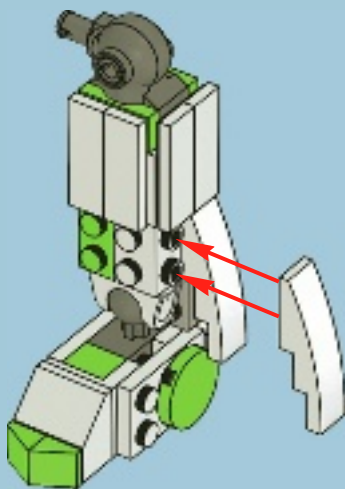

1x

11

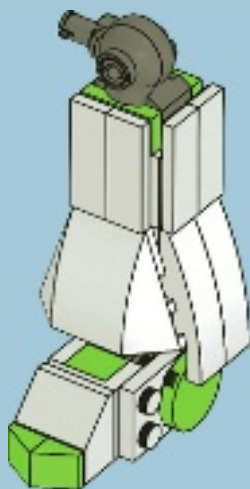

12

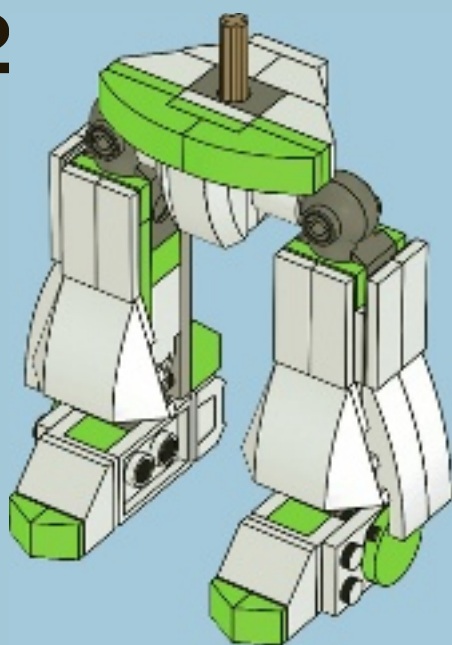

13

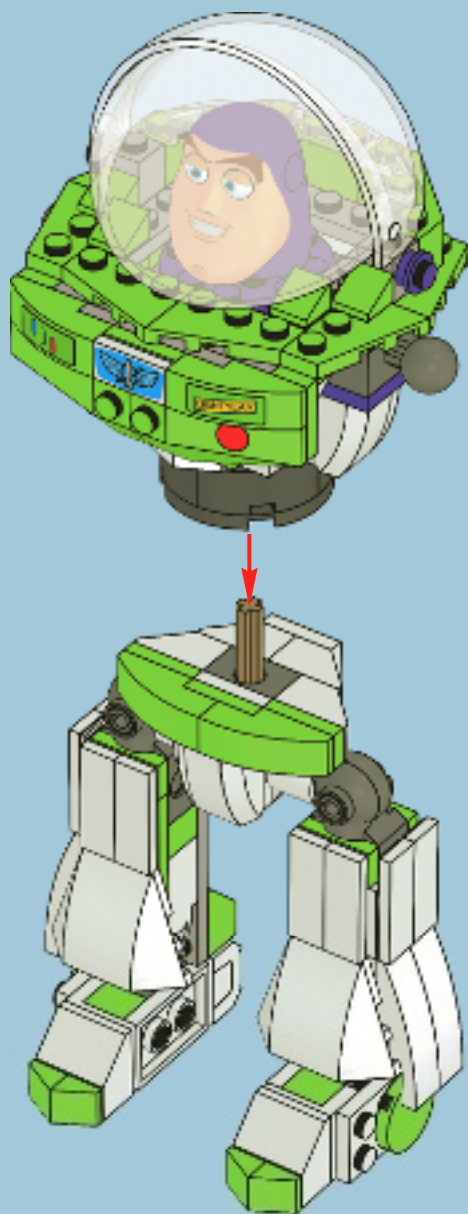



1x



1x



1x



1x



1x



2x



1x



1x

14

1



2

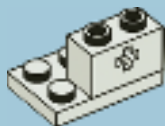

3

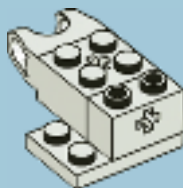

4



5



6

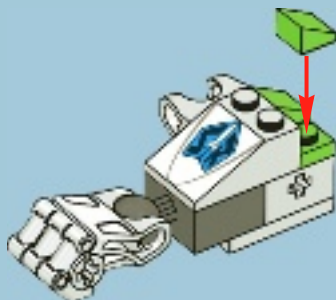

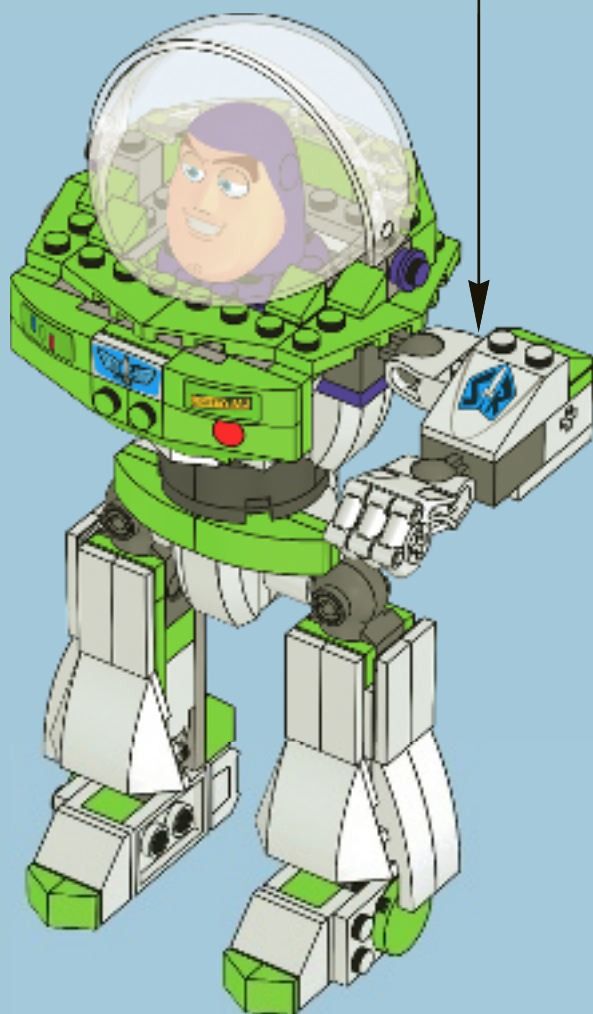



1x



2x



1x



1x



1x



1x



1x



1x



1x



1x

15

1

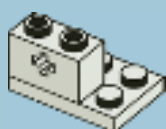

2

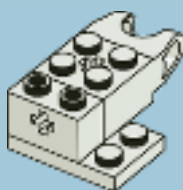

3



4



5

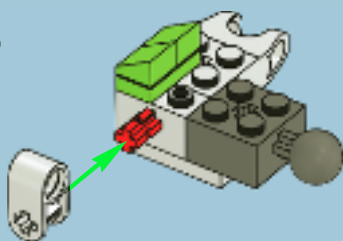

6

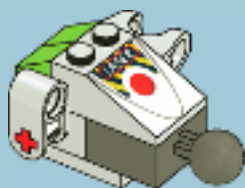

7

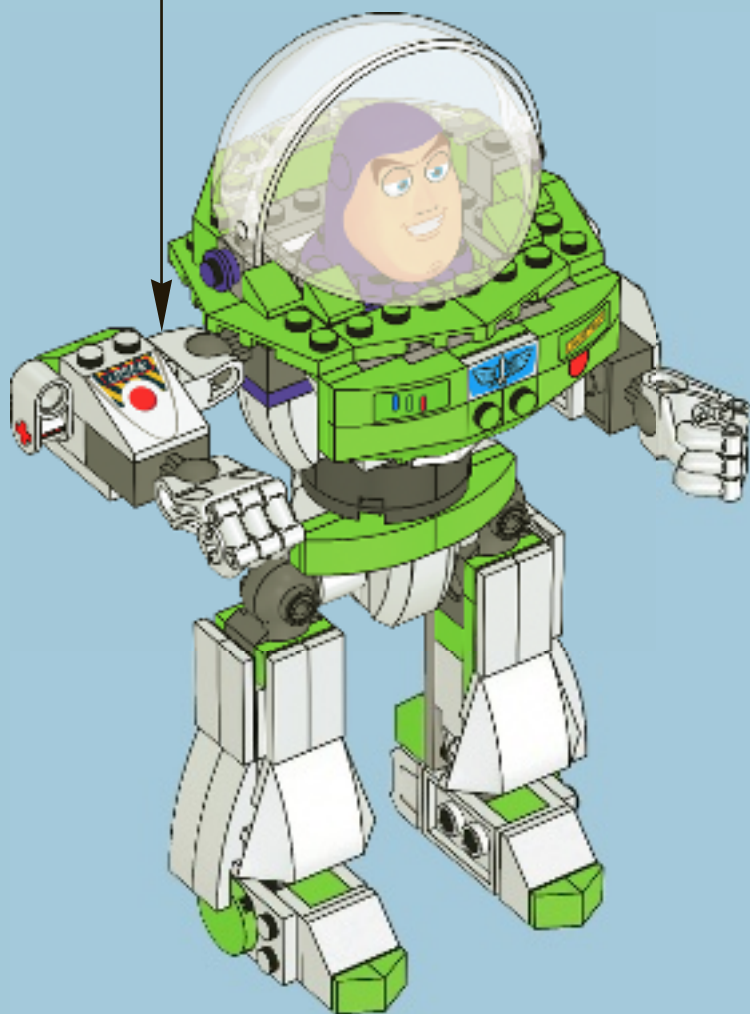
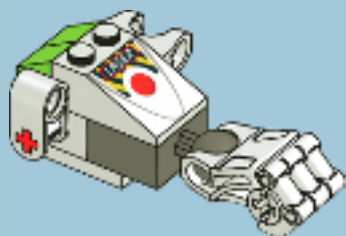



1x



1x

16

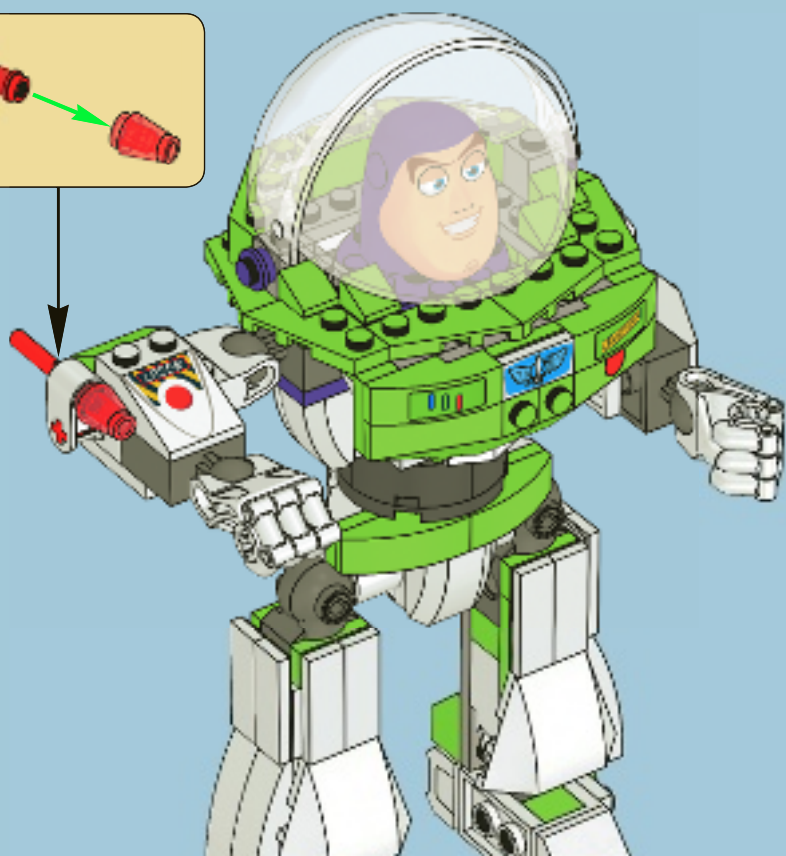
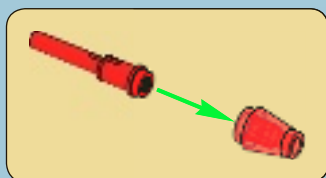



1



2





1x



2x

3

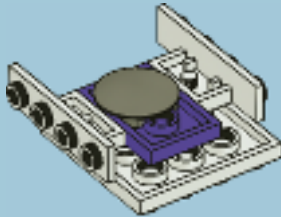

2x

4

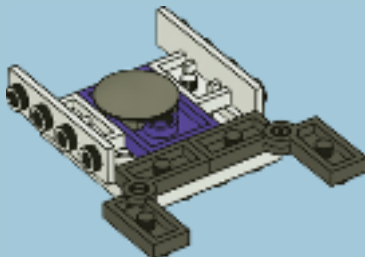

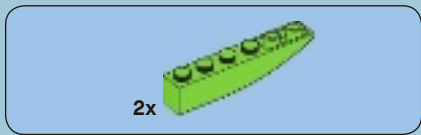

5

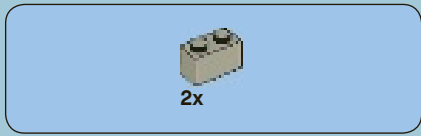
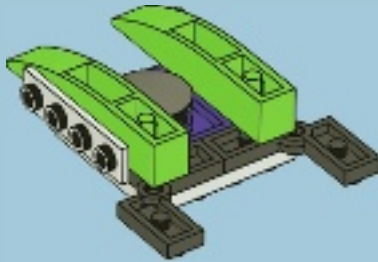

6

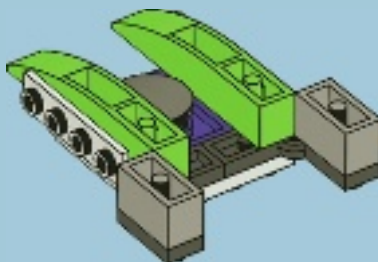



2x

7

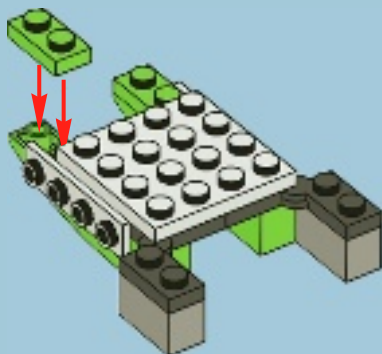

2x

8

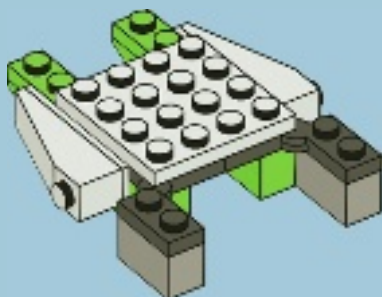

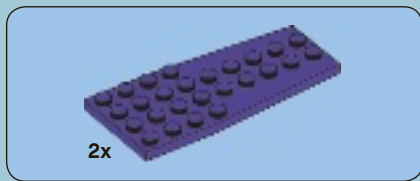

9

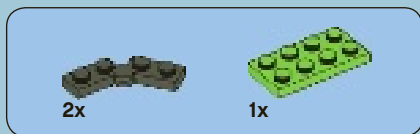
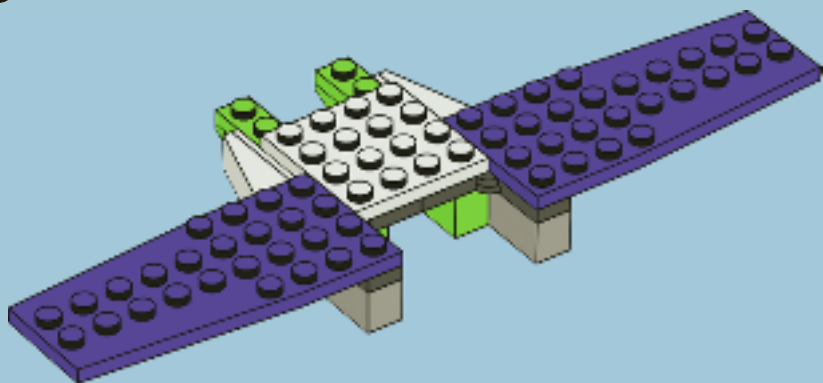

10

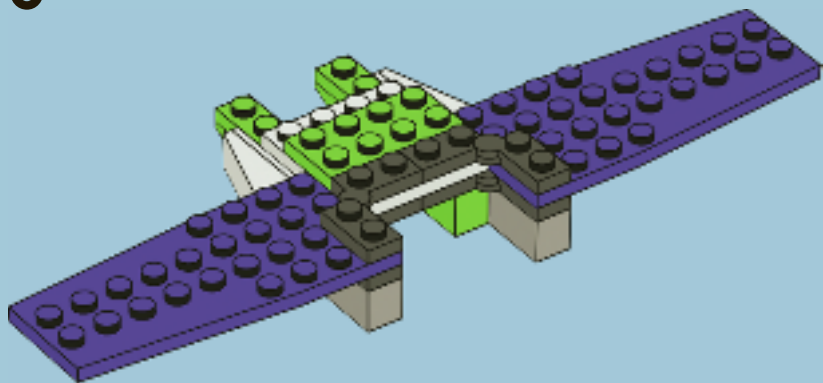

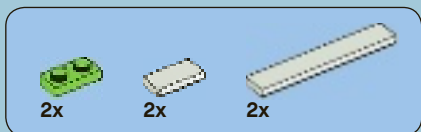

11

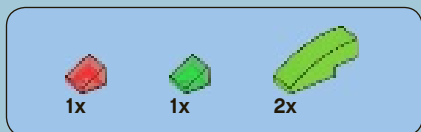
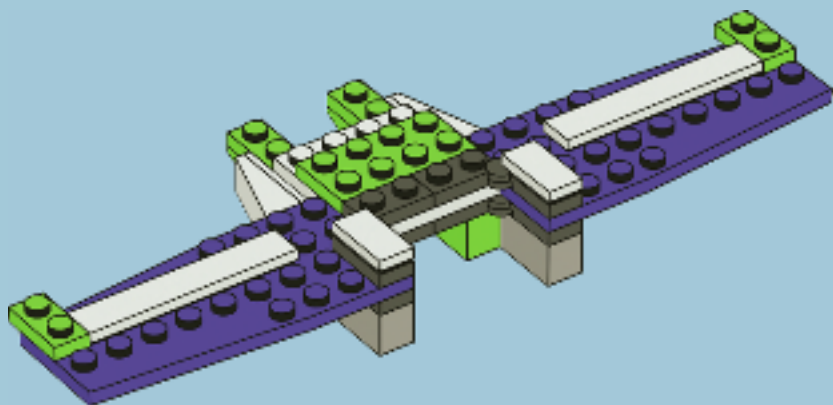

12

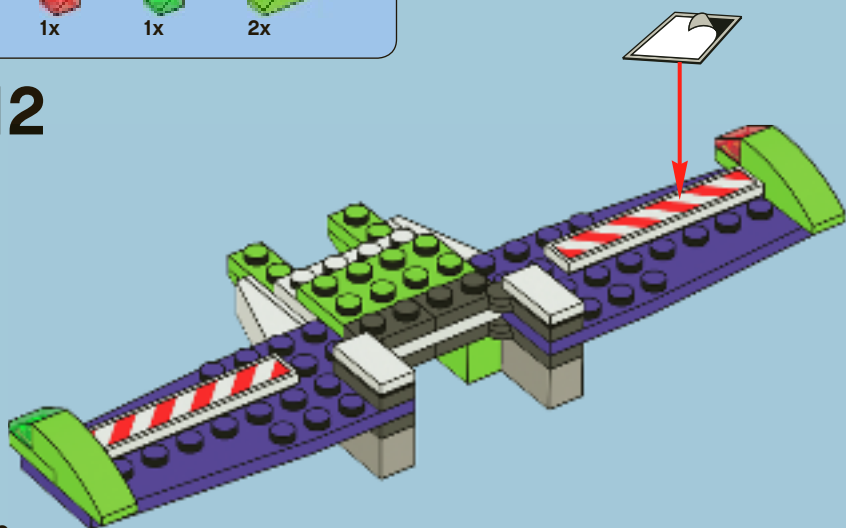

13

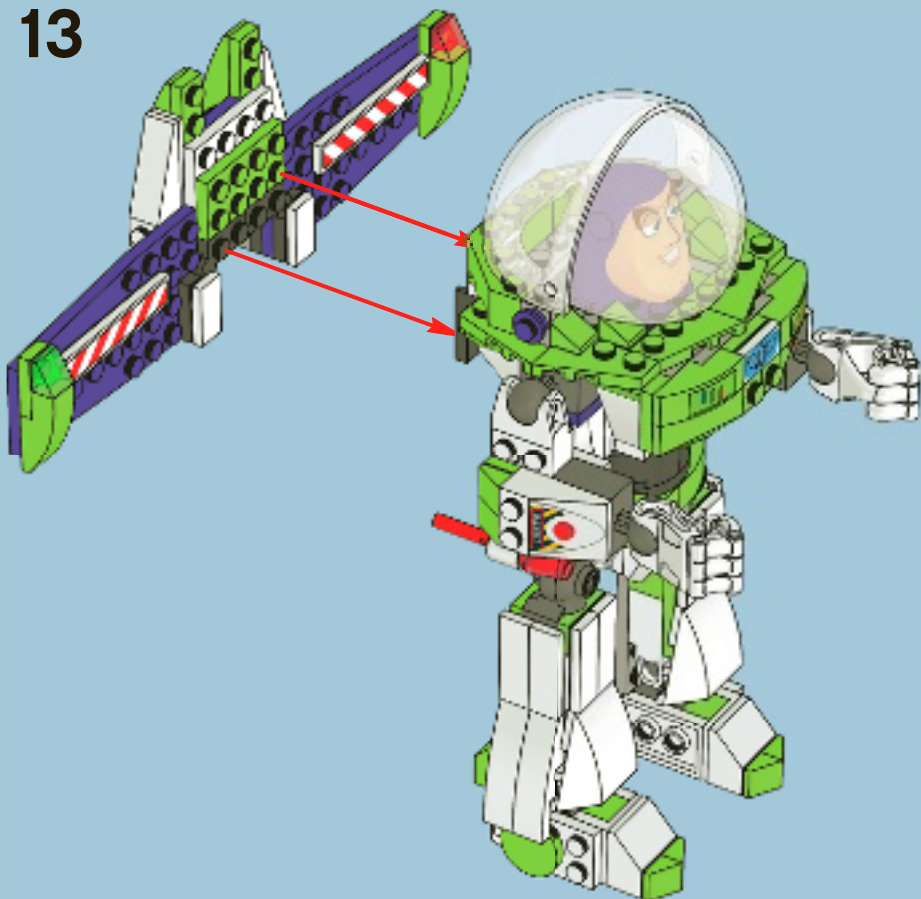



Disney · PIXAR
**TOY
STORY**

7590



7594



7593



7595



LEGO and the LEGO logo are trademarks of the LEGO group.
©2010 The LEGO group.
© Disney/Pixar.



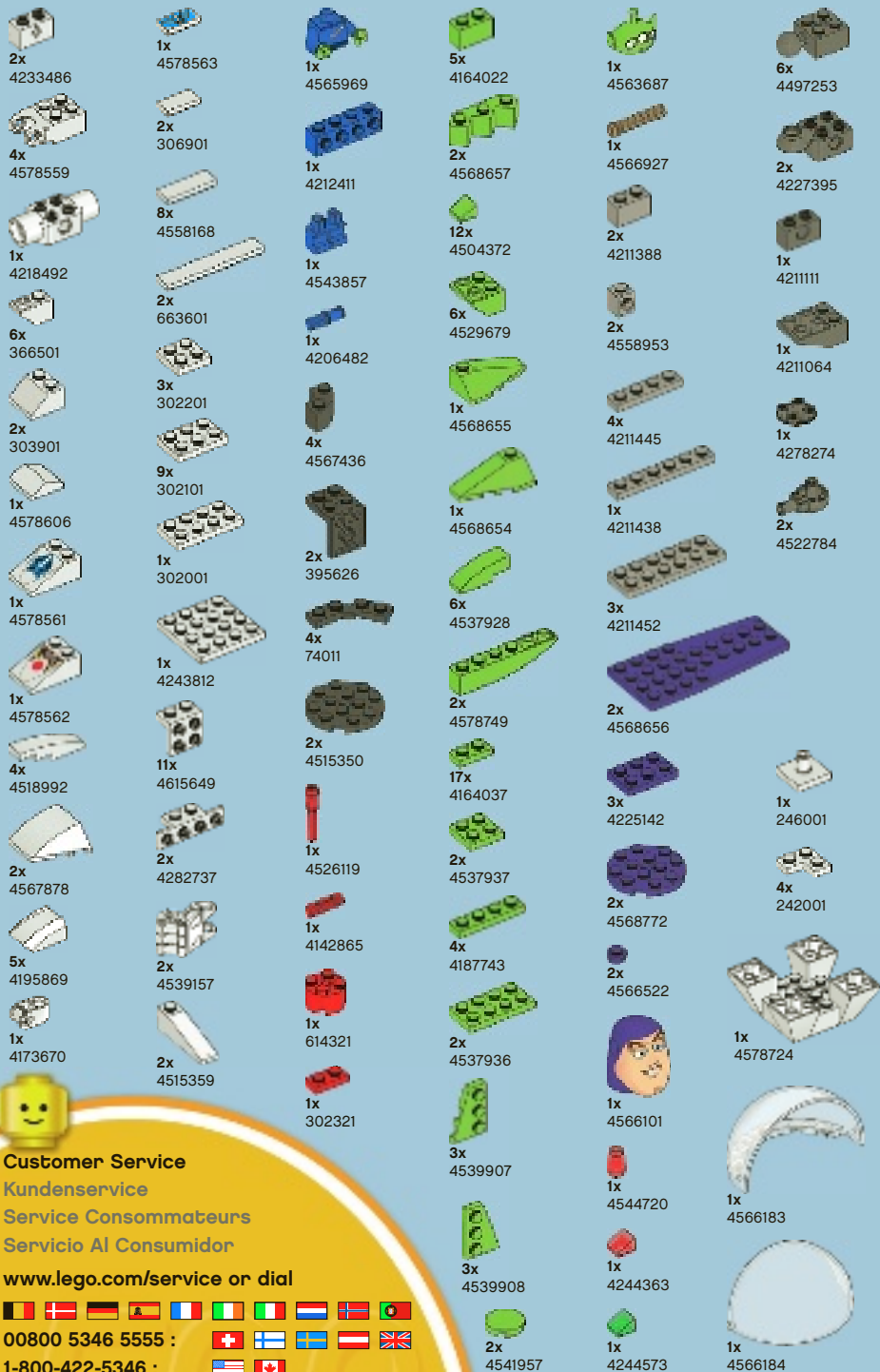

Customer Service

Kundenservice

Service Consommateurs

Servicio Al Consumidor

www.lego.com/service or dial



00800 5346 5555 :



1-800-422-5346 :



FREE! GRATIS! GRATUIT!

LEGO

club
MAGAZINE™

www.LEGOclub.com



00800 5346 5555*



1-866-534-6258 • 1-877-518-5346

US & Canada only

Canada seulement

* Freephone. Mobile charges may apply. * Numéro sans Frais. Des Frais peuvent s'appliquer avec les téléphones cellulaires.
* Gebührenfrei, Kosten für Anrufer aus Mobilfunknetzen können abweichen. * Gratis telefoonnummer vanaf vaste lijn.
* Det er ett gratis nummer, när du ringer Fra Fasttelefon. * Det är gratis, när du ringer Från en Fast telefon.



VISIT THE WORLD'S
BIGGEST LEGO® SHOP!

www.LEGOshop.com



WIN!

Go to www.nielsen.com/LEGO
to fill out a survey for a chance
to win a cool LEGO® Product.

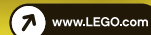

No purchase necessary.
Open to all residents where not prohibited.



www.nielsen.com/LEGO

GEWINNE!

Nimm an der Umfrage auf
www.nielsen.com/
LEGO teil und hab die Chance ein cooles
LEGO Produkt zu gewinnen!

Die Teilnahme am Gewinnspiel führt zu keinerlei
Kaufverpflichtungen. Teilnahme in allen nicht
ausgeschlossenen Ländern möglich.

WIN!

Ga naar www.nielsen.com/LEGO,
vul een enquêteformulier in en
maak kans op een
cool LEGO® product.

Geen aankoopverplichting.
Iedereen mag deelnemen, uitgezonderd
ingezetenden
van landen waar een enquêteverbod geldt.

GAGNE!

Visite www.nielsen.com/LEGO
pour répondre à un questionnaire
et avoir une chance de gagner
un produit LEGO® très cool!

Aucune obligation d'achat.
Ouvert à tous les résidents des pays
autorisés.

当てよう!

www.nielsen.com/LEGO
にアクセスして、
アンケートにご記入ください。
当選者にはレゴ®製品を
差し上げます。

お買い上げの必要はありません。
禁止されていない限り、すべての皆様にご利用いただけます。